

The Scuttlebutt

The Official Publication of the Scioto Model "A" Ford Club

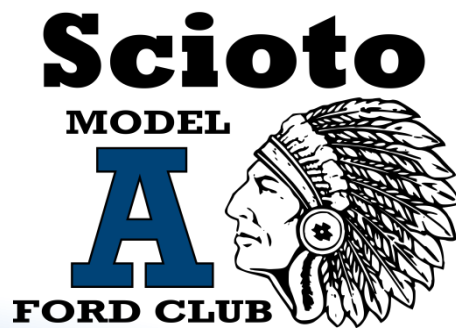

MARC Central Ohio Region
Columbus, Ohio

October 2023

Cover Photo

This month's cover photo was taken at Coney Island in Cincinnati, Ohio. It features one of the many beautiful vehicles on the Grand Tour during the 2023 MARC National Meet.



The Chief's Corner

Hello Everyone!

Here is a final report on the MARC membership question that we have been wrestling with this year. The officers of the club have concluded that MARC is not requiring all of its affiliate members to join MARC, and no action by the club is necessary. If a club member wishes to be covered by MARC liability insurance while participating in a sanctioned event, they must be a member of MARC. If they choose to not be a MARC member, they will be relying on their own insurance. That said, as an affiliate of MARC, we need to be doing a better job of promoting membership in our National club.

Although our touring season is rapidly winding down, we still have a lot of events planned. We have been invited to a new "Pop Up" event at the Friendship Village of Dublin, located at 6000 Riverside Drive. It will be held on Friday, October 6th, from 10:00 a.m. to 12:00 noon. The Retirement Community will be holding its annual "Street Fair" and the residents would enjoy seeing some of our Model A's.

On October 7th, we have our auction and cookout at Steve and Jaci Rohner's. Bring some cash, a covered dish, a chair, and any auction items you might want to contribute.

Our final Fall Tour will be on Saturday, October 21st. Steve Baldwin will be leading us through the covered bridges of Fairfield County to the historic Rock Mill. The leaves should be turning. Don't forget to bring a picnic lunch.

Wednesday, November 1st, will be a dinner meeting at which time we will be electing our 2024 officers. Details will be forthcoming.

And finally, be sure to register for the Delaware Veterans Parade on Sunday November 5th.

Wayne

2023 Officers

President: Wayne Davis
Vice President: Jim Jones
Treasurer: Spencer Cheek
Secretary: Pat Liston

2023 Trustees

1st Year: Jaci Rohner
1st Year: Vacant
2nd Year: Clark Garn
2nd Year: Chip Stout

2023 Directors

Technical Director: Rick Lindner
Regional Director: David Kauffman
Sunshine Director: Kathy Bickley
Newsletter Editor: Allan D. Goldhardt

Contact Information

Email: SciotoModelA@gmail.com
Website: www.TheModelAClub.org
Facebook: Scioto Model A Club
(closed group)
Telephone: (614) 204-1070
US Mail: The Scioto Model "A" Club
C/o Pat Liston
751 S. State Route 605
Sunbury, Ohio 43074

October Birthdays

Kristen Conrad
Darlene Jones
Dave Rothert
Dick Luckhaupt
David Kauffman
Mary Lou Gearhart
Monroe Harbage

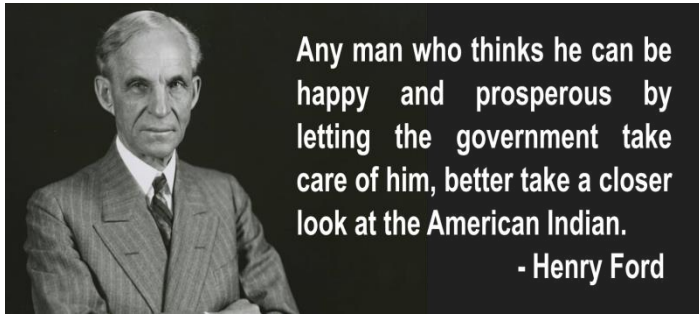

Any man who thinks he can be happy and prosperous by letting the government take care of him, better take a closer look at the American Indian.

- Henry Ford

Our Next Meeting

DATE: October 7, 2023
TIME: 12:00 noon
PLACE: Steve Rohner's Garage
LOCATION: 7083 St. Rt. 142 SE
West Jefferson, Ohio
TOPIC: Club Auction, Cookout, & Nomination of Officers

DIRECTIONS:

1. Take I-270 to the west side.
2. Get off at Exit 7 – Route 40 (West Broad Street).
3. Go west on Route 40 for 8 miles to Route 142 in West Jefferson.
4. Take Route 142 south for about 2 miles.
5. Steve & Jaci's place is on the left hand side.

ADDITIONAL INFORMATION:

This is our annual auction, cookout & potluck. Be sure and bring your own chair to sit on. Also bring a side dish to share with everyone!

FALL ROCK MILL TOUR

On October 21st, Steve Baldwin will be leading the Scioto Model "A" Ford Club on the Fall Rock Mill Tour. We will gather at the Marathon Station across from the Scioto Downs Casino located on Route 23 at 5991 South High Street. We will leave promptly at 9:00 a.m. and head to Fairfield County to check out some of their many covered bridges. We will make a stop in Rushville, Ohio at the Hugus Cider Mill. From there, we will go to Rock Mill. Rock Mill was built in 1824 and served as a flour and gristmill for many years. It is now part



of the Fairfield County Park System. We will enjoy a picnic lunch while at Rock Mill. Everyone is to bring their own lunch, drinks, and chairs. This is sure to be a fun tour with a lot of sites to see. Be sure to save the date and plan to attend the Fall Rock Mill Tour and Picnic!



FROM THE DESK OF

Pat Liston

SECRETARY

August Secretary's Report

This is a summary of the Tech Meeting that took place at Bill Liberto's Garage on Sept 6th. We had a great turnout of about 25 people, including our new member, Thomas Lehman. We hope you enjoyed the meeting and the delicious food provided by Christine, who catered meatball sliders and turkey sliders, coconut cake, deviled eggs, cheese cubes and German potato salad. We also had a variety of water and sodas to quench our thirst. We are grateful to Bill and Christine for their hospitality and generosity.

Our President, Wayne Davis, started the meeting by welcoming everyone and introducing Thomas Lehman to the group. He also thanked those who joined the Cottrill Sculpture Studio and Gallery Tour on August 19th and shared some highlights from the event.

Unfortunately, Spencer Cheek, our treasurer, could not attend the meeting, so we did not have a treasurer report. We will update you on the financial status of the group in the next meeting.

We also did not hear from the Sunshine Committee, so we encourage you to contact Kathy Bickley if you have any news or updates to share with the group.

Our Secretary, Pat Liston, did not have any remarks on the minutes that were published in the Scuttlebutt that was emailed late due to some issues with our September 23rd tour. It seems it has been a fluctuating situation all month. That made it difficult for Allan Goldhardt, newsletter editor, to send out the newsletter with precise information. Secretary Liston distributed new name badges for our new member, Tom Lehman.

We will have a pop-up Tour on September 20th at 11:30 a.m. to Shawnee Hills. We will meet at the Boston Stoker Coffee Bar located at 6058 Glick Road in Shawnee Hills.

President Davis announced that he will be leading us to Rosco Village on September 23rd. We might have a chance to take a canal boat ride while we are there. He also has a nice place for us to stop for lunch and ice cream afterwards. We will meet at the Sheetz gas station located at 9905 Johnstown Road in New Albany.

We will have our Annual Auction on October 7th at noon. This is a fantastic opportunity to buy or sell some Model A parts and accessories. The location will be at Steve Rohner's Garage, 7083 State Route 142 SE., West Jefferson, Ohio. Please bring your items to auction and some cash to bid.

We will go to Rock Mill on October 21st. This is a scenic tour that will take us to the historic covered bridges of Fairfield County. We will also visit Hugus Cider Mill in East Rushville, Ohio, where you can buy some fresh apple cider and other goodies. We will meet at 9 a.m. at the Marathon Station, across from the casino, located at 5991 South High St., Columbus. Steve Baldwin will be our leader for this tour. Please bring a picnic lunch to enjoy at the Rock Mill.

Next, we want to update you on the officers' inquiry into the MARC membership requirement. We contacted the MARC administrators and checked the MARC insurance information online. We have confirmed that Marc membership is required to be covered by their insurance if an accident occurs during a tour. However, MARC membership is not required to participate in our club activities. We encourage you to join MARC if you have not already done so, as it provides many benefits and supports the preservation of Model "A" cars. We urge new members to sign up to MARC. We will include that information in our Welcome Letters. We also need to collect the Member ID of those who are currently MARC Members. MARC will request that information before providing coverage.

We also want to remind you of some important updates and events for our club. First, we are looking for a volunteer who can take on the role of club historian and help us preserve and organize our club's history. This is an important and rewarding task that will benefit our club for years to come. If you are interested, please contact us and we will provide you with more details.

Second, we are getting ready for our officer nominations at our October Tech Meeting. This is a chance for you to step up and contribute to the growth and success of our club. We have several positions available and we welcome anyone who wants to run. The elections will take place at our November Tech Meeting.

President Davis then turned the meeting over to Bill to discuss ignition switches, but he turned the meeting over to Conrad Gerdes from Dillsboro, Indiana who spoke about things you can do to your car and carry for tours that keep them running. He gave us some useful tips and tricks on how to keep our Model "A" cars running smoothly and safely. I especially enjoyed Conrad's presentation on electronic ignitions and how they can improve the performance of our cars. Conrad gave us a good presentation. Thank you Conrad, for all you do for Model "A" Clubs.

Then Dick Liston spoke about a tool he found most handy in balancing and tow-in. He explained the process to those interested. Thank you Bill, Conrad, Dick, and Wayne for all your helpful information and thank you Christine for the fine food. Great meeting and everyone learned a lot!

I want to thank President Davis again for organizing the Roscoe Village Tour. It was a wonderful day of learning and fun. We visited several historical buildings that gave us a glimpse of life in the late 1800s and early 1900s. We also had a relaxing boat ride on the Canal Boat, pulled by two majestic Clydesdale horses. The weather was perfect, and the scenery was beautiful. It was a wonderful way to spend a day with our fellow Model "A" enthusiasts. Thank you, Wayne, for your excellent planning and execution!

Have a Great Day!

SCIOTO MODEL "A" FORD CLUB SCHEDULE

<p style="text-align: center;"><u>October</u></p>	<p style="text-align: center;"><u>November</u></p>
<p>3rd - 6th <u>Eastern Fall Meet</u> Hershey, Pennsylvania</p> <p>7th - <u>Club Auction & Cook-Out - Noon*</u> Steve Rohner's Garage 7083 St. Rt. 142 SE, West Jefferson</p> <p>21st - <u>Rock Mill Tour*</u> Lancaster, Ohio</p>	<p>1st - <u>Tech Meet – 7:00 pm*</u> Station House 11 Front Street, Commercial Point</p> <p>12th - <u>Veteran's Day Parade*</u> Delaware, Ohio</p>
<p style="text-align: center;"><u>December</u></p> <p>1st - <u>Christmas Party</u> Boat House 679 W. Spring Street, Columbus</p>	<p style="text-align: right;">* Points Events</p>

"A" Word on Fashion

Menswear

The most significant development in men's fashion during the 20's occurred in two unique kinds of trousers: the Oxford bags and the plus-fours. Oxford bags grew in popularity around 1924-25 when undergraduates at Oxford adopted these wide-legged trousers. Though the origin of the style is contentious, it is generally agreed that it derived from the trousers that rowers on Oxford's crew teams pulled on over their shorts, and you can see how "The Bystander" satirized this in 1924. The original style was about 22 inches wide at the bottom, several inches wider than the average men's trouser leg. Oxford undergraduates began wearing these around the university and soon the style spread. As the style spread, so too did the width of the trouser legs until at one point they reached up to 44 inches wide. The trousers were made out of flannel and came in a variety of colors. They were mostly worn by youths, perhaps the male counterparts of the Flapper, and became a favorite of Britain's "Bright Young People," a group of wealthy, aristocrats known for their antics in London's nightlife.





ANNUAL CLUB AUCTION



It is once again time for our club's yearly auction. This year's auction will be held on Saturday, October 7th, at 12:00 noon at Steve & Jaci Rohner's garage. Their garage is located on 7083 St. Rt. 142 SE in West Jefferson, Ohio. You will need to bring your own lawn chair to sit on during the auction.

If you have any unused Model "A" or Model "T" parts that you would like to donate to the club, and help our club in the process, now is the time. This auction is not limited only to auto related items. If you have any other household items that you would like to donate, the club will gladly accept them as well.

The club auction, yearly membership dues, and the 50/50 raffles are the only source of income for our club. Holding a club auction gives our membership a chance to clear their garages of unwanted items. It also gives other members a chance to pick up something they may need for their "A" at a bargain price, in addition to raising money for our club treasury. The club auction is always a good time and a win for everyone. So gather up your stuff and plan to attend the Annual Club Auction next month!

MAFFI Newsletter Minute

Model "A" Days (September 15th & 16th, 2023) were a resounding success! The weather was a perfect 70 degrees, so all those open Model "A" cars that came to show themselves off for the theme this year had no trouble with the weather at the museum. In fact, the grounds were full of all types of Model "A"s driven onto the Gilmore grounds by hobbyists!

The "first start" Model "A" Coupe took just 43 minutes to start up after being abandoned more than 30 years and being in a flood up to the windshield. This year there were TWO first starts; the second was a truck (AA) and that only took a tad over 10 minutes to start up. There's no shortage of crackerjack mechanics at Model "A" Days.

The Model "A" school bus and Stake Bed truck were kept busy carrying passengers around the 90-acre grounds and the riders had great fun smiling and waving. For the second year in a row, the Model "A" Driving School graduated a new batch of Model "A" drivers, so we can keep those inner tube tires rolling!

And there were lots of new Model "A" Ford Foundation Inc. red t-shirts and navy hoodies being worn by our loyal museum supporters. If you were there, you would know how much fun was had. If you didn't make it, pencil in your calendar for next year, September 20th & 21st, 2024!

Happy motoring!

Mike DuBreuil, Secretary
MAFFI Board of Trustees

NATIONAL EVENTS

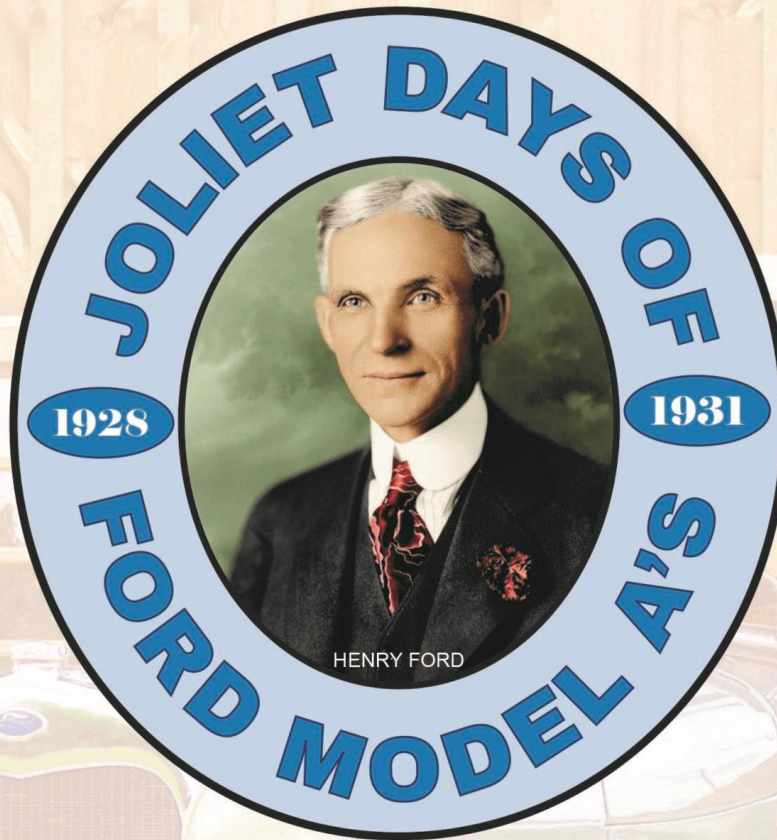

MARC MEMBERSHIP MEET

APRIL 4 - 7, 2024

JOLIET, ILLINOIS

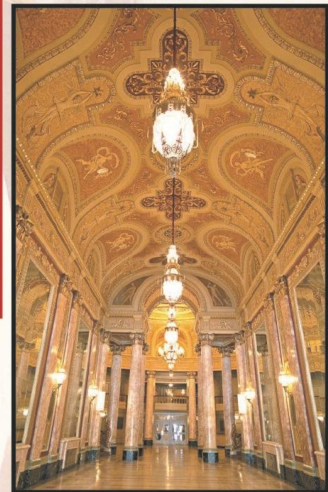
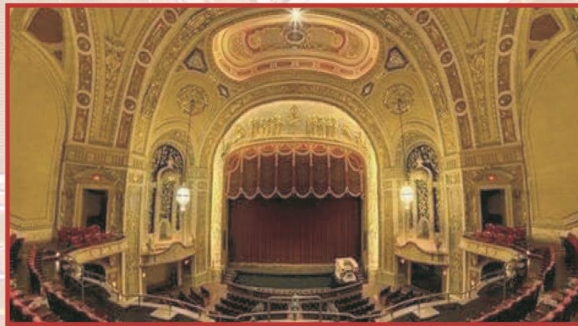
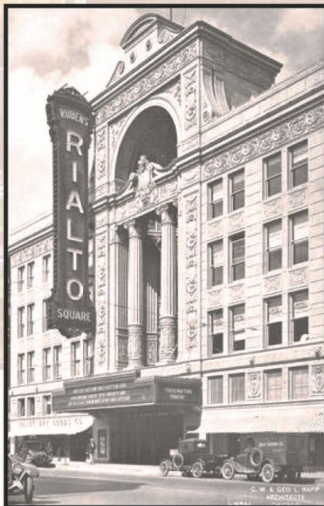

Hosted By The JOLIET REGION of the MODEL 'A' RESTORERS CLUB

ACCOMMODATIONS:

A special group rate of \$139/night has been arranged at the Holiday Inn & Suites: Joliet Southwest

To get this special rate call (779) 206-2915 and mention MARC or visit www.ihg.com and enter the following:

Destination: Joliet, IL; Check-in/Check-Out Dates; # Rooms & Guests;

From the dropdown Rate Preference menu choose Group Rate, enter code MCR then click Search.

Choose Holiday Inn & Suites: Joliet Southwest (1471 Rock Creek Blvd., Joliet, IL 60431)

September Tech Meet

Editor
Scioto Model "A" Ford Club

Last month, on the 6th of September, the Scioto Model "A" Ford Club held their monthly meeting in Hilliard, Ohio at Bill Liberto's Garage. It was a beautiful summer evening. We had around 25 members come to the Tech Meet. Christine Liberto served up plenty of great food for everyone. President Davis called the meeting to order. After the business portion of the meeting, Bill Liberto introduced Conrad Gerdes of Indiana. Conrad gave us many tips and tricks for our Model "A"s. When Conrad finished, Dick Liston explained how to adjust the toe-in on a Model "A". The entire meeting was very interesting and informative. A big "Thank You" goes out to Conrad, Dick, Bill, and Christine for sharing their knowledge and their hospitality. Our next meeting will be Saturday, October 7th, at 12:00 noon at Steve Rohner's Garage in West Jefferson, Ohio. This will be our annual auction & potluck. We will also be nominating officers for 2024. Be sure to bring a dish to share and a chair to sit on. This is



DELAWARE COMMUNITY

VETERANS PARADE

OUR THEME FOR THE PARADE THIS YEAR IS VIETNAM

HONORING ALL WHO SERVED

PLEASE HELP US WELCOME HOME OUR VIETNAM ERA VETERANS

The Parade will step off from the Delaware County Fairgrounds, travel down Pennsylvania Avenue towards Downtown Delaware, head south on Sandusky Street, and end near OWU on Wilmer Street

**SUNDAY
NOVEMBER 5,
2023 - 3:00**



**DOWNTOWN
DELAWARE
RAIN OR SHINE**

ALL VETERANS ARE WELCOME TO JOIN US!
PARTICIPATE ★ VOLUNTEER ★ ATTEND ★ SPONSOR

**JOIN US FOR THE VETERAN'S SOCIAL 12:00 TO 2:30 PM IN THE JR. FAIR BUILDING
LIGHT LUNCH, COFFEE AND DESSERTS TO BE SERVED
FOOD - FELLOWSHIP - FUN**

The Social is open to the public. Please come thank a Veteran!

Registration forms are available at: Delaware Library Main Branch - 84 E Winter Street, Delaware
& Delaware Veterans Service Office - 149 North Sandusky Street, Delaware

Please note the deadline to register is 5:00 PM on Friday, November 3, 2023

Like and Follow us on Facebook: [Delaware, Ohio Veterans Day Parade](#)

Questions: DelawareVeteransParade@Yahoo.com

Kindly help us get the word out about the parade by sharing the registration form, the details about the parade with your family & friends, or your own groups and organizations and neighbors.

Have you thanked a Veteran for their service today?





BACKYARD TECH TIP



ELECTRONIC IGNITION?

Some Model "A" owners try to correct hard-to-start problems by installing an electronic ignition. Often a Model "A" that's hard to start on points will be just as hard to start on an electronic ignition system if the problem wasn't the points. All an electronic ignition system does is replace the points and condenser. An electronic ignition does not give you higher spark voltage, eliminate all maintenance on your ignition system, or give enough of a horsepower boost to cause the car to do wheelies. It replaces the points. That's it. It will not correct or overcome other major problems in the ignition system. While it will give you more horsepower and improve your fuel economy, both would be so insignificant as to be hardly noticeable on a 40 horsepower engine. As the analogy goes, putting electronic ignition on an 85+ year old car is like putting 12" woofers on your grandfathers 78 rpm Victrola and expecting it to sound like surround sound. While it is certainly true that an electronic ignition system is superior when compared to a points ignition system, that's beside the point. The question is the practical applicability of an electronic ignition on an 85+ year old, 40 horsepower, low compression, low rpm engine. The key advantage to an electronic ignition system is that you do not need to gap & lube the points every year or replace them every four to five years. If your distributor is within specs, you perform annual maintenance on the points, and change them every four years or so using quality parts, you will see no difference whatsoever between a points ignition system or an electronic ignition system on a Model "A". The key disadvantages to an electronic ignition on a Model "A" are the initial costs, it will not work with a low battery voltage, and it is easily damaged beyond repair by polarity reversal and other common mistakes, and it could leave you stranded on the roadside unless you opt to carry a spare electronic ignition module. If you have a well running car and just don't care to fool with the points anymore, an electronic ignition is a perfect alternative. If you expect an electronic ignition to cure any significant ignition problem you may have other than bad points, it won't. This is the question you need to answer: "If tens of thousands of other Model "A"s operate just fine on a 6-volt system with points, why can't mine?"



Model "A" Youth News!

In last month's newsletter, I included a couple pictures that I took at the MARC National Meet showing an activity they had for all of the kids that attended. They let the kids disassemble a Model "A" that already had the body removed. This month, I am including a couple more pictures from that activity.

Editor
Scioto Model "A" Ford Club



Here are a couple future Model A'ers removing a front bumper. Does anyone recognize that guy in the background in the picture on the left?



LOCAL EVENTS

NO ONLINE OR PRE REGISTRATION.



LANCASTER CAR SCENE 2ND ANNUAL CAR-TOBERFEST

OCTOBER
22ND

REGISTRATION
\$ 15

- TOP 100
- BEST JEEP
- BEST MUSCLE
- BEST TRUCK
- VETERAN CHOICE
- BEST BIKE
- FOOD, DRINKS, 50/50
- GIVEAWAYS



CAR SHOW

REG. NOON-3 AWARDS AT 5
3560 DOLSON CT. CARROLL, OH



WSO

westerville special olympics

Carshow

\$10 To Enter
Spectators are free
All Vehicles Welcome



Food Trucks
From 11am-2pm



Trophies



Raffle

Dash Plaques

October 1st 9am-2pm

Sponsored By **Roush Honda**
An Employee-Owned Company

**5885 Westerville Rd.
Westerville OH, 43081**

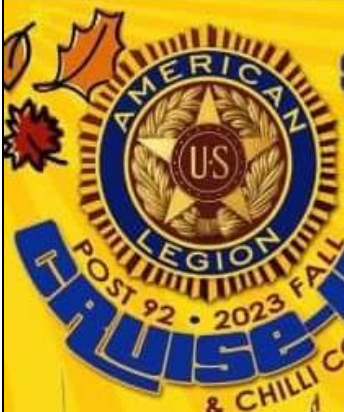

AMERICAN LEGION POST 92 • 2023 FALL

HOUSE

& CHILI COOK-OFF

SATURDAY OCTOBER 28th
9^{am}-3^{pm}

**CARS • TRUCKS
TRACTORS
MOTOR CYCLES**



OPEN FOR DRINKS
GRILL BRATS/BURGERS
BUCKEYE GAME
TRICK OR TREAT FOR KIDS
PUMPKIN CARVING
COSTUMES WELCOME

10 S Washington St
Utica, OH 43080
(740) 892-3435

EMPTY POCKETS CRUISERS

10TH ANNUAL TRUNK OR TREAT CAR SHOW

DATE: 10/21/2023
REGISTRATION: FROM 11AM-1PM
REGISTRATION FEE: \$10
AWARDS: AT 3PM



COLUMBUS, OHIO
Est. 2014

All Years, Makes & Models Welcome
100 Dash Plaques & 50 Awards
Door Prizes, Music, Food & Drinks

**3600 LEAP RD
HILLIARD, OHIO 43026**

Presenting Sponsor:



ROBINSON REAL ESTATE GROUP
Renae Robinson 614-402-9100
Sami Rivas Martinez 614-413-5719



Howard Hanna
Real Estate Services

Pre-Register Now
\$12 Pre-Registration \$15 On-site

@ carshowpro.com/events/view/1049
carshow@tollestech.com



6th annual tollestech Car & Craft Show

October 7, 2023

Interested in a Craft Show Booth?
www.tollestech.com
for details and registration form

KSM YOUTH SPORTS

KSM
YOUTH SPORTS

SUMMER CAMP & AFTER SCHOOL

TRUNK OR TREAT CAR SHOW!



BENEFITING THE CURE STARTS NOW!

SUNDAY OCT 15TH 3-5PM

FUN & SAFE! | CANDY! | FOOD! | AND MUCH MORE!

**YOUR ENTIRE FAMILY IS WELCOME!
HURRY AND SAVE YOUR CHILDS SPOT!**

www.powelltrunkortreat.com

Questions? Call or Text (614) 313-0304
10336 Sawmill Rd. Powell, OH 43065

How the Model “A” Came to have a Zenith Carburetor

In April of 1927, Harold Hicks was called from his work in aircraft engineering to a meeting with Edsel Ford and Rough production bosses, Charles Sorensen and Peter Martin. They showed Hicks a 203 cubic inch displacement engine that was only developing twenty-two horsepower. They asked him how much he could get out of the engine.

After a few calculations, Hicks told them that he could get forty horsepower and that it would take about three weeks to do the job. Given the assignment, Hicks, working closely with Carl Schultz, concentrated on changing the manifold and carburetor. He also opened up the passages around the exhaust valves and changed the shape of the gasket.

Within three weeks, the engine was developing the promised forty horsepower. After exhaustive dynamometer testing, even Henry Ford was convinced that Hicks had kept his promise.

To achieve his results, Hicks had used a standard Zenith carburetor, which was held together by fourteen small screws. Finally, Charles Sorensen said, “Get the Zenith company in here for a final design”. Henry Ford said he didn’t want the carburetor to have the test model’s fourteen screws. Zenith changed the design and made it so it was held together by only two bolts. Henry said that was too many, and so the Model “A” carburetor came to be held together by only one bolt.

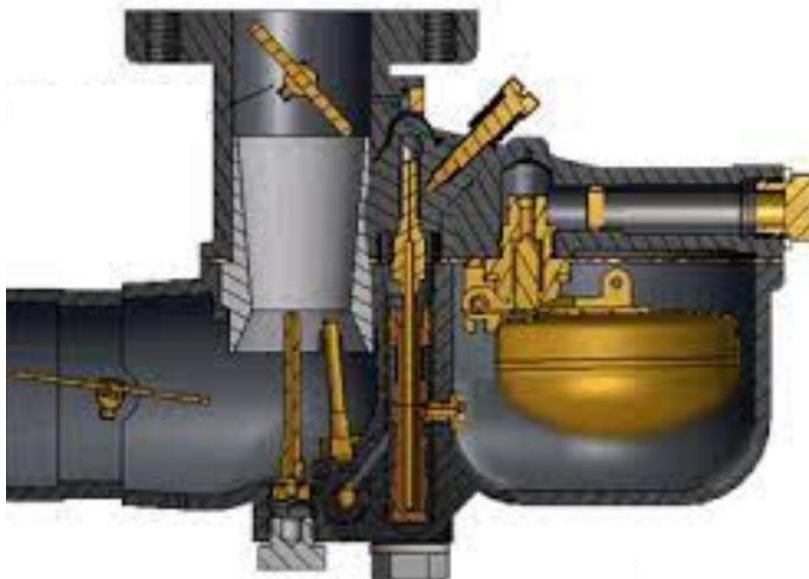

Main Assembly Bolt

Submitted by Rick Lindner

Adapted from “The Legendary Model A Ford” by Peter Winnewisser.



Did you know that the Scioto Model “A” Club has a Facebook page? It is a closed group, so only our members may view the page. If you would like to see what’s going on, just log on to Facebook and go to the Scioto Model A Club. Once there, click on “Join the Group”. After the moderator of our group approves your membership, Facebook sends you a notification of the approval and group posts immediately begin to appear in your news feed.

Presenting
The
FLAPPER of the MONTH



This month we feature Betty Blythe. She was born in 1893 as Elizabeth Blythe Slaughter in Los Angeles. Betty had shortened her name to Betty Blythe when she and three other women posed for a photo shoot of the newest swim fashion for women, a bathing suit. Previously, women were expected to wear stockings with full dresses or skirts into the water. Blythe worked in vaudeville singing songs. In 1915, she had an unbilled part for Famous Players Film Company. After her first Vitagraph Studios role in 1917, she was given a leading role in a 1918 film. As famous for her revealing costumes as for her dramatic skills, she became a star in such exotic films as "The Queen of Sheba" in 1921 wearing nothing above the waist except a string of beads. She continued to work as a character actress. One of her later roles was a small, uncredited role in a crowd scene in 1964's "My Fair Lady". Blythe was married to a movie director from 1919 until his death in 1954. She reportedly made \$3.5 million when she sold a section of land that is now part of the Sunset Strip. She lost her fortune in the 1929 stock market crash. She died of a heart attack in Woodland Hills, Los Angeles, in 1972 at the age of 78.

THE END

